



ZHEJIANG HANGCHA IMP. & EXP. CO., LTD.

**Factory site:** 666 Xiangfu Road,  
Hangzhou, Zhejiang, China (311305)

Tel: +86-571-88926735 88926755  
Fax: +86-571-88926789 88132890

sales@hcforklift.com  
www.hcforklift.com



2017 VERSION 1.1/COPYRIGHT 2017/12



HANGCHA trucks conform to the European Safety Requirements.

HANGCHA GROUP CO., LTD. reserves the right to make any changes without notice concerning colors, equipment, or specifications detailed in this brochure, or to discontinue individual models. The colors of trucks, delivered may differ slightly from those in brochures.



## J Series Electric Forklift Truck

with capacities of 8,000 to 10,000kg

[8000kg @900mm , 9000/10000kg @600mm]

*The World of Hangcha*



## Appearance

/ Body choosing modern large circular arc streamline surface modeling, is in accordance with international design trend.

## Comfortable

/ Soft landing system is applied for it, when the fork lows to 100-500mm to ground, the soft landing system is auto operated, it can avoid the forks dashing against the ground.

/ New dashboard is easy to see and provides friendly human-computer interaction with multiple functions.

/ Low noise, energy saving and no exhaust emission, all meet the environment friendly requirement.

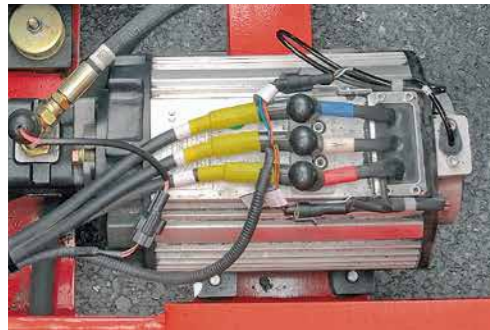

/ Steering braking and lifting hydraulic adopts two independent hydraulic system, to ensure the braking performance, realize the joint operations.



/ The front-rear type designed battery layout technology provides excellent stability.



/ Ergonomically designed adjustable angle of steering wheel, and 150mm adjustable distance of seat, both provide better operator's comfort of different operators.



/ International advanced Full-AC controller can control the travelling, lifting, braking and turning action. It provides stable and accurate control, speed control performance is superior, regenerative braking, reverse connect braking, anti-slope and other functions, make the operation more efficient, safe and comfortable.

Front dual tyre



## Standard specification

- / Full-AC motor & controller
- / Multi-function dashboard
- / Full electric controlled travelling, lifting, steering and braking
- / Front light system, turning indicator, combined rear light
- / Standard battery
- / Emergency switch
- / Reversing beeper
- / Full hydraulic steering and braking
- / Suspension seat
- / Soft landing system
- / 3m duplex wide view mast
- / Standard forks
- / Super elastic solid tyre
- / Left and right rear view mirror
- / Toolbox
- / Pin

## Options

- / Big capacity import battery
- / Charger
- / Rear working light
- / Colored solid tyre
- / Duplex mast with full free lift
- / Triplex mast with full free lift
- / Other length fork
- / Wider or higher load backrest
- / Attachments

## Battery

Capacity(Ah/5h)	8t	9t	10t
900	○		
960	●	○	
1104	○	●	○
1260	○	○	●

Note: ● STD. ○ OPT.



Small dimension solid tyre



You can open the door on each side, it make the motor, oil pump and electrical controller maintenance is very convenient, provide good waterproof and dustproof



New designed broad view mast provides better forward view ability



Full opened battery cover is easy for battery service

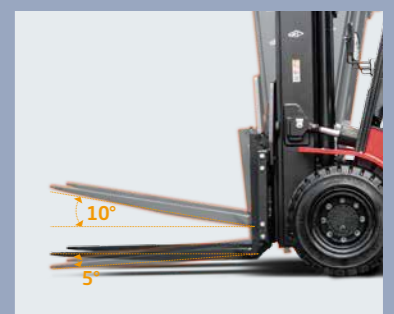

## J series 8.0-10t electric forklift specification

Distinguishing mark	1.1	Manufacturer	HANGCHA GROUP CO.,LTD.			
	1.2	Manufacturers type designation	CPD80J-L	CPD90J	CPD100J	
	1.5	Load capacity/rated load	Q (kg)	8000	9000	10000
	1.6	Load centre distance	c (mm)	900	600	600
	1.8	Load distance, centre of drive axle to fork	x (mm)	680	680	690
	1.9	Wheelbase	y (mm)	2500	2500	2500
Weight	2.1	Service Weight (Include battery box)	kg	13500	13800	14200
Tyres, chassis	3.2	Tyre size, front		8.25-15	8.25-15	300-15
	3.3	Tyre size, rear		250-15	250-15	250-15
	3.5	Wheels, number front / rear (x = driven wheels)		4x/2	4x/2	4x/2
	3.6/3.7	Tread(Front/Rear)	b10/b11(mm)	1489/1460	1489/1460	1493/1460
Dimensions	4.1	Tilt of mast/fork carriage forward/backward	$\alpha/\beta(^{\circ})$	5/10	5/10	5/10
	4.2	Height, mast lowered	$h_1$ (mm)	2700	2700	2700
	4.3	Free lift	$h_2$ (mm)	200	200	200
	4.4	Lift	$h_3$ (mm)	3000	3000	3000
	4.5	Height, mast extended	$h_4$ (mm)	4530	4530	4530
	4.7	Height of overhead guard STD.	$h_6$ (mm)	2550	2550	2550
	4.8	Seat height	$h_7$ (mm)	1410	1410	1410
	4.20	Length to face of forks	$l_2$ (mm)	3755	3755	3755
	4.21	Overall width	$b_1$ (mm)	1970	1970	2040
	4.22	Fork dimensions ISO2331	s/e/l (mm)	80/200/1800	70/200/1200	80/170/1200
	4.23	Fork carriage DIN 15 173 --- ISO 2328, class/type A,B		4A	4A	5A
	4.25	Distance between fork-arms	$b_5$ (mm)	410/1800	410/1800	350/1800
	4.32	Ground clearance, centre of wheelbase	$m_2$ (mm)	190	190	190
	4.34.1	Aisle width for pallets 1000 x 1200 crossways	$A_{st}$ (mm)	5440	5440	5450
	4.34.2	Aisle width for pallets 800 x 1200 lengthways	$A_{st}$ (mm)	5640	5640	5650
4.35	Turning radius	$W_a$ (mm)	3560	3560	3560	
Performance Data	5.1	Travel speed, laden/unladen	km/h	13/15	13/15	13/15
	5.2	Lift speed, laden/unladen	m/s	0.3/0.44	0.28/0.4	0.26/0.37
	5.3	Lowering speed, laden/unladen	m/s	0.5/0.4	0.47/0.39	0.45/0.38
	5.7	Gradeability, laden/unladen	%	13/15	12/14	12/14
Electric engine	6.1	Drive motor rating S2 60 min	kW	35	35	35
	6.2	Lift motor rating at S3 15%	kW	52	52	52
		Steering motor	kW	3	3	3
	6.4	Battery voltage, nominal capacity K5	V/Ah	96/960	96/1104	96/1260
8.1	Type of drive control		MOSFET/AC	MOSFET/AC	MOSFET/AC	
9.1	Manufacturer		CURTIS	CURTIS	CURTIS	
10.1	Operating pressure for attachment	Mpa	19	19	18.5	

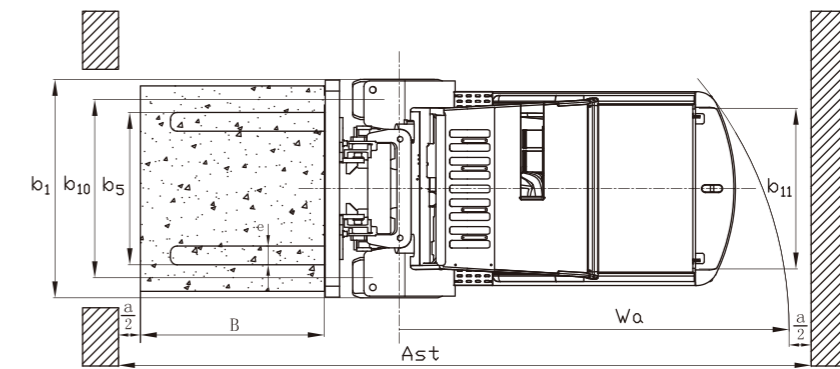
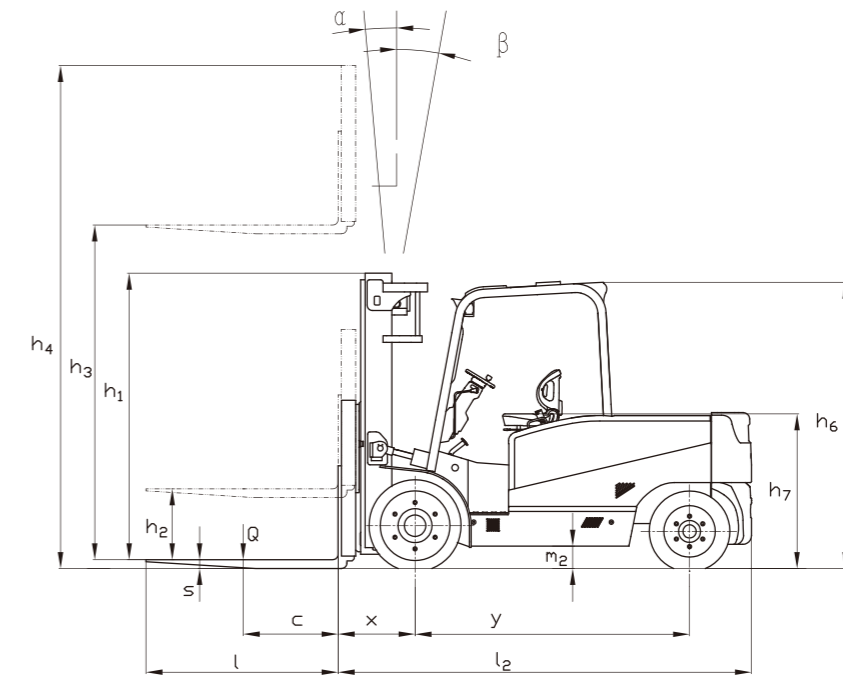

$$A_{st} = B + W_a + x + a$$

$a = 200\text{mm}$  Safety clearance

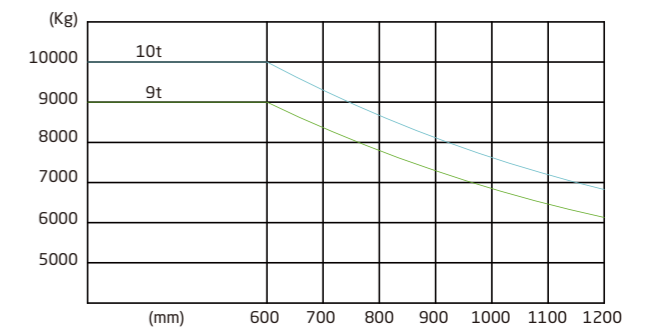
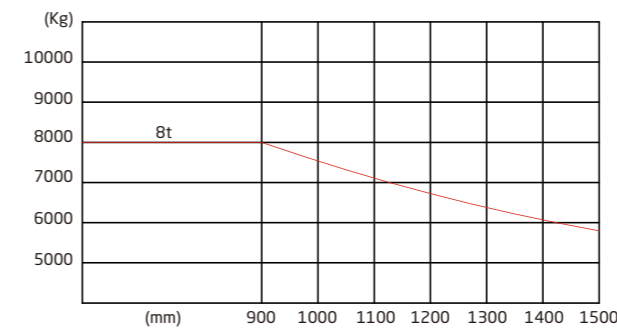



**Easy/  
Efficiency/  
Economy**

### Advanced

- / Big LCD dashboard is easy to see and provides friendly human-computer interaction and with running hours, self-diagnosis function and mode selection.
- / Regenerative brake(When parking, reversing and declining, the drive motor will charge the battery, energy saving).
- / Energy saving LED lamp.

### Reliability & Safety

- / Motor controller, contactor, power plug, emergency switch, instrument and other major electrical components adopt international brand products.
- / Electronic and hydraulic overload protection device.
- / CE Certification.

### AC Advantages

- / Three motors are all Full-AC, free maintenance, low cost.
- / High efficiency AC system with full protection functions provides reliability and long working life.



## 8t Mast specification

Type	Max. lifting height	Overall height				Free lift			Tilting range	Capacity
		Lowered	Extended		Without backrest	With backrest	Overhang	F/R		
			Without backrest	With backrest						
	mm	mm	mm	mm	mm	mm	mm	(°)	kg	
Duplex wide view mast	2500	2450	3900	4030	200	200	690	5/8	8000	
	2700	2550	4100	4230	200	200	690	5/8	8000	
	3000	2700	4400	4530	200	200	690	5/10	8000	
	3300	2850	4700	4830	200	200	690	5/10	8000	
	3600	3000	5000	5130	200	200	690	5/10	7900	
	4000	3200	5400	5530	200	200	690	5/10	7700	
	4300	3400	5700	5830	200	200	690	5/8	7500	
	4500	3500	5900	6030	200	200	690	5/8	7500	
	4800	3650	6200	6330	200	200	690	5/8	7200	
	5000	3750	6440	6530	200	200	690	5/8	7200	
	5500	4050	6900	7030	200	200	690	5/8	6800	
	6000	4300	7400	7530	200	200	690	5/8	6600	
Duplex full-free mast	2500	2450	3900	4030	1060	930	710	5/8	8000	
	2700	2550	4100	4230	1160	1030	710	5/8	8000	
	3000	2700	4400	4530	1310	1180	710	5/10	8000	
	3300	2850	4700	4830	1460	1330	710	5/10	8000	
	3600	3000	5000	5130	1610	1480	710	5/10	7900	
	4000	3200	5400	5530	1810	1680	710	5/10	7700	
	4300	3400	5700	5830	2010	1880	710	5/8	7500	
	4500	3500	5900	6030	2110	1980	710	5/8	7500	
	4800	3650	6200	6330	2260	2130	710	5/8	7200	
	5000	3750	6440	6530	2360	2230	710	5/8	7200	
	5500	4050	6900	7030	2660	2530	710	5/8	6800	
	6000	4300	7400	7530	2910	2780	710	5/8	6600	
Triplex full-free mast	4500	2850	6055	6030	1305	1305	760	5/8	7250	
	4800	2950	6355	6330	1405	1405	760	5/8	6950	
	5000	3050	6555	6530	1505	1505	760	5/8	6950	
	5500	3200	7055	7030	1655	1655	760	5/8	6550	
	6000	3350	7555	7530	1805	1805	760	5/8	6350	

## 9t Mast specification

Type	Max. lifting height	Overall height				Free lift			Tilting range	Capacity
		Lowered	Extended		Without backrest	With backrest	Overhang	F/R		
			Without backrest	With backrest						
	mm	mm	mm	mm	mm	mm	mm	(°)	kg	
Duplex wide view mast	2500	2450	3900	4030	190	190	680	5/8	9000	
	2700	2550	4100	4230	190	190	680	5/8	9000	
	3000	2700	4400	4530	190	190	680	5/10	9000	
	3300	2850	4700	4830	190	190	680	5/10	9000	
	3600	3000	5000	5130	190	190	680	5/10	8900	
	4000	3200	5400	5530	190	190	680	5/10	8700	
	4300	3400	5700	5830	190	190	680	5/8	8500	
	4500	3400	5900	6030	190	190	680	5/8	8500	
	4800	3650	6200	6330	190	190	680	5/8	8200	
	5000	3750	6440	6530	190	190	680	5/8	8200	
	5500	4050	6900	7030	190	190	680	5/8	7800	
	6000	4300	7400	7530	190	190	680	5/8	7600	
Duplex full-free mast	2500	2450	3900	4030	1060	930	710	5/8	9000	
	2700	2550	4100	4230	1160	1030	710	5/8	9000	
	3000	2700	4400	4530	1310	1180	710	5/10	9000	
	3300	2850	4700	4830	1460	1330	710	5/10	9000	
	3600	3000	5000	5130	1610	1480	710	5/10	8900	
	4000	3200	5400	5530	1810	1680	710	5/10	8700	
	4300	3400	5700	5830	2010	1880	710	5/8	8500	
	4500	3500	5900	6030	2110	1980	710	5/8	8500	
	4800	3650	6200	6330	2260	2130	710	5/8	8200	
	5000	3750	6440	6530	2360	2230	710	5/8	8200	
	5500	4050	6900	7030	2660	2530	710	5/8	7800	
	6000	4300	7400	7530	2910	2780	710	5/8	7600	
Triplex full-free mast	4500	2850	6055	6030	1305	1305	760	5/8	8250	
	4800	2950	6355	6330	1405	1405	760	5/8	7950	
	5000	3050	6555	6530	1505	1505	760	5/8	7950	
	5500	3200	7055	7030	1655	1655	760	5/8	7550	
	6000	3350	7555	7530	1805	1805	760	5/8	7350	

## 10t Mast specification

Type	Max. lifting height	Overall height				Free lift			Tilting range	Capacity
		Lowered	Extended		Without backrest	With backrest	Overhang	F/R		
			Without backrest	With backrest						
	mm	mm	mm	mm	mm	mm	mm	(°)	kg	
Duplex wide view mast	2500	2450	3900	4030	200	200	690	5/8	10000	
	2700	2550	4100	4230	200	200	690	5/8	10000	
	3000	2700	4400	4530	200	200	690	5/10	10000	
	3300	2850	4700	4830	200	200	690	5/10	10000	
	3600	3000	5000	5130	200	200	690	5/10	9900	
	4000	3200	5400	5530	200	200	690	5/10	9700	
	4300	3400	5700	5830	200	200	690	5/8	9500	
	4500	3500	5900	6030	200	200	690	5/8	9500	
	4800	3650	6200	6330	200	200	690	5/8	9200	
	5000	3750	6440	6530	200	200	690	5/8	9200	
	5500	4050	6900	7030	200	200	690	5/8	8800	
	6000	4300	7400	7530	200	200	690	5/8	8600	
Duplex full-free mast	2500	2450	3900	4030	1060	930	710	5/8	10000	
	2700	2550	4100	4230	1160	1030	710	5/8	10000	
	3000	2700	4400	4530	1310	1180	710	5/10	10000	
	3300	2850	4700	4830	1460	1330	710	5/10	10000	
	3600	3000	5000	5130	1610	1480	710	5/10	9900	
	4000	3200	5400	5530	1810	1680	710	5/10	9700	
	4300	3400	5700	5830	2010	1880	710	5/8	9500	
	4500	3500	5900	6030	2110	1980	710	5/8	9500	
	4800	3650	6200	6330	2260	2130	710	5/8	9200	
	5000	3750	6440	6530	2360	2230	710	5/8	9200	
	5500	4050	6900	7030	2660	2530	710	5/8	8800	
	6000	4300	7400	7530	2910	2780	710	5/8	8600	
Triplex full-free mast	4500	2850	6055	6030	1305	1305	760	5/8	9250	
	4800	2950	6355	6330	1405	1405	760	5/8	8950	
	5000	3050	6555	6530	1505	1505	760	5/8	8950	
	5500	3200	7055	7030	1655	1655	760	5/8	8550	
	6000	3350	7555	7530	1805	1805	760	5/8	8350	